

MAXIBAG



- Maximise the possibilities for a variety of applications
- Attractive design & adaptable functionality
- User-friendly, reliable snap-shut catches
- Rectangular design optimises use of interior space
- Durable living hinge
- Surface finish suited to printing / branding
- Moulded in tough ABS (Acrylnitril-Butadien-Styrol) material
- Scuff resistant surface
- For further custom options please contact us



Maxibag with high density custom foam interior. Medical instrument.



Maxibag with customised PU foam interior.

available in 26 sizes



MAXIBAG	0,3-67	0,4-79	0,5-91	0,5-111	0,5-131	0,8-54	0,8-65	0,8-76		0,8-106	0,8-117	0,8-158	1-81	1-96	1-111	1,5-131	1,5-167	1,5-202
Black Catches red	9510000	9511000	9512000	9513000	9514000	9515000	9516000	9517000		9518000	9519000	9520000	9521000	9522000	9523000	9524000	9525000	9526000
Blue Catches black	9510011	9511011	9512011	9513011	9514011	9515011	9516011	9517011		9518011	9519011	9520011	9521011	9522011	9523011	9524011	9525011	9526011
Light grey Catches blue	9510022	9511022	9512022	9513022	9514022	9515022	9516022	9517022		9518022	9519022	9520022	9521022	9522022	9523022	9524022	9525022	9526022
Red Catches black	9510031	9511031	9512031	9513031	9514031	9515031	9516031	9517031		9518031	9519031	9520031	9521031	9522031	9523031	9524031	9525031	9526031
Ext. Dim mm (L x B x H)	254 x 230 x 72	271 x 241 x 84	289 x 256 x 97	289 x 256 x 117	289 x 256 x 137	345 x 308 x 61	345 x 308 x 72	345 x 308 x 83		345 x 308 x 113	345 x 308 x 124	345 x 308 x 164	390 x 334 x 88	390 x 334 x 103	390 x 334 x 118	432 x 363 x 138	432 x 363 x 174	432 x 363 x 209
Max. Int. mm (L x B)	248 x 176	265 x 187	283 x 202	283 x 202	283 x 202	339 x 248	339 x 248	339 x 248		339 x 248	339 x 248	339 x 248	384 x 274	384 x 274	384 x 274	425 x 304	425 x 304	425 x 304
Min. Int. mm (L x B)	246 x 173	262 x 184	280 x 198	280 x 196	278 x 196	337 x 246	337 x 245	336 x 245		337 x 242	336 x 242	332 x 242	381 x 271	381 x 269	379 x 269	420 x 298	420 x 294	416 x 294
Height Int. Dim. (Total = Base HB + Lid HL)	67 - 33,5 + 33,5	79 - 39,5 + 39,5	91 - 45,5 + 45,5	111 - 65,5 + 45,5	131 - 65,5 + 65,5	54 - 27 + 27	65 - 38 + 27	76 - 38 + 38		106 - 79 + 27	117 - 79 + 38	158 - 79 + 79	80 - 40 + 40	96 - 56 + 40	111 - 55,5 + 55,5	131 - 65,5 + 65,5	167 - 101 + 66	202 - 101 + 101
Empty Weight kg approx.	ca. 0,4	ca. 0,5	ca. 0,6	ca. 0,6	ca. 0,7	ca. 0,7	ca. 0,7	ca. 0,8		ca. 0,9	ca. 0,9	ca. 1,0	ca. 1,0	ca. 1,0	ca. 1,1	ca. 1,4	ca. 1,5	ca. 1,7

Accessories

- Lid stays
- Divider board
- Document file
- Trolley
- Shoulder strap
- Foam sets

Range of colours*

Standard colours Catches



* Customized colours on request

Size details

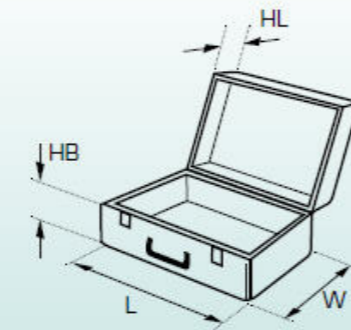

HB Height Base / HL Height Lid

2-81	2-102	2-122	2-137	2-157	2-192	3,5-162	3,5-197	3,5-232
9527000	9528000	9529000	9530000	9531000	9532000	9533000	9534000	9535000
9527011	9528011	9529011	9530011	9531011	9532011	9533011	9534011	9535011
9527022	9528022	9529022	9530022	9531022	9532022	9533022	9534022	9535022
9527031	9528031	9529031	9530031	9531031	9532031	9533031	9534031	9535031
452 x 383 x 89	452 x 383 x 109	452 x 383 x 129	452 x 383 x 144	452 x 383 x 164	452 x 383 x 200	539 x 450 x 169	539 x 450 x 205	539 x 450 x 240
445 x 323	445 x 323	445 x 323	445 x 323	445 x 323	445 x 323	531 x 380	531 x 380	531 x 380
442 x 320	442 x 318	440 x 318	442 x 314	440 x 314	437 x 314	524 x 373	524 x 370	521 x 370
81 - 40,5 + 40,5	102 - 61 + 41	122 - 61 + 61	137 - 96 + 41	157 - 96 + 61	192 - 96 + 96	162 - 81 + 81	197 - 116 + 81	232 - 116 + 116
ca. 1,3	ca. 1,4	ca. 1,5	ca. 1,6	ca. 1,7	ca. 1,8	ca. 2,3	ca. 2,5	ca. 2,7